

Indexing Plungers

Stainless Steel, with Chamfered Pin, with and without Rest Position

SPECIFICATION

Types

- Type **B**: Without rest position, without lock nut
- Type **BK**: Without rest position, with lock nut
- Type **C**: With rest position, without lock nut
- Type **CK**: With rest position, with lock nut

Guide

Stainless steel AISI 303 **NI**

Plunger pin

Stainless steel AISI 431, hardened

Knob

Plastic (Polyamide PA)

- Black, matte finish
- Not removable

Grub screw DIN 916

Stainless steel AISI 304

Compression spring

Stainless steel AISI 301

Hex nut ISO 8675

Stainless steel AISI 304



INFORMATION

Indexing plungers GN 824 have a plunger pin with square cross-section, a latching surface on one side and a chamfer on the other. When the object to be secured moves towards the chamfer, the plunger pin is pushed back into the guide, allowing grooves and edges to pass over the pin. The latching can be released by pulling the knob.

Type C / CK indexing plungers with rest position are used for applications when the plunger pin is temporarily not to engage. In that case, the knob is retracted and afterwards turned by 90°. A notch keeps the plunger in this position.

When the grub screw is not tightened, the orientation of the bevel can be freely adjusted over a range of 360°. This can be identified by the marking on the indexing plunger guide.

- Range of indexing plungers (see page 738)

ACCESSORY

- Distance Bushings GN 609.5 (see page 810)

TECHNICAL INFORMATION

- ISO-Fundamental Tolerances (see page A21)
- Plastic Characteristics (see page A2)
- Stainless Steel Characteristics (see page A26)

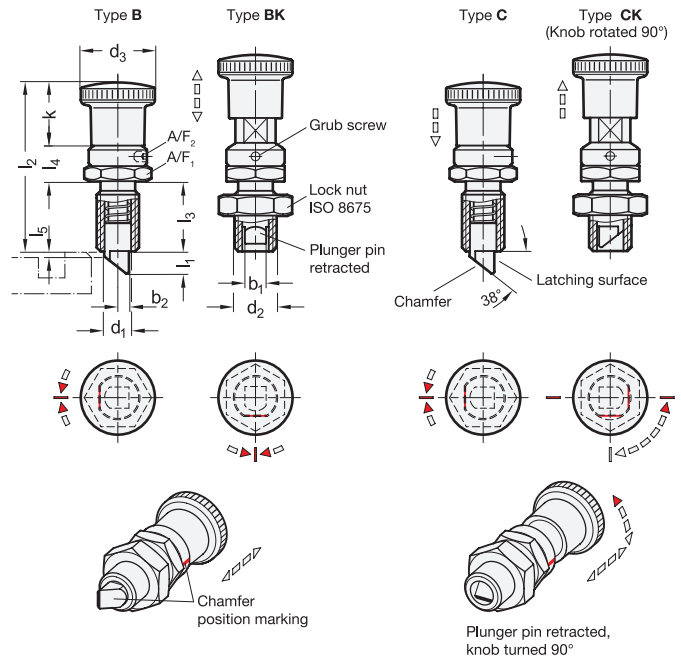

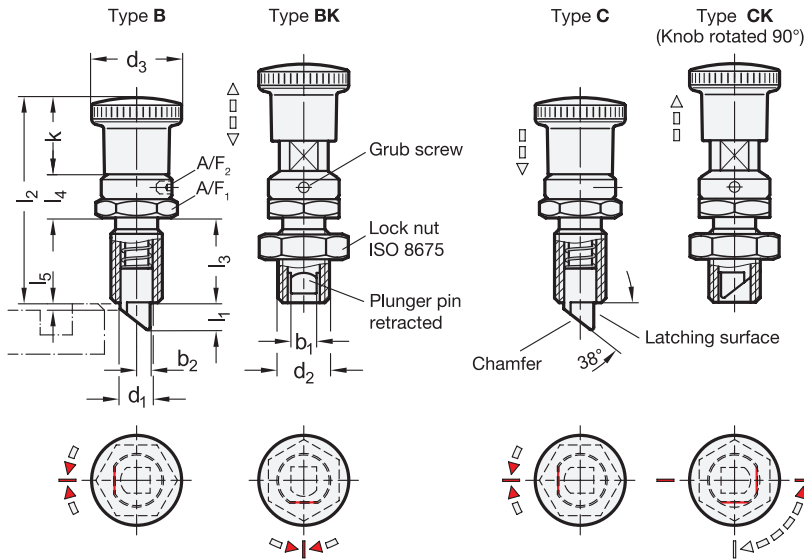

GN 824-B

STAINLESS STEEL

Description	b1	l1	b2	d1 Plunger -0.02/-0.04 Bore H8	d2	d3	k	l2	l3	l4	l5	A/F1	A/F2	Spring load in N≈ Initial	Spring load in N≈ End	⚖️
GN 824-5-5-B-NI	5	5	2.5	7	M 12 x 1.5	23	20	51.3	20	11.3	1	17	2	9	18	48
GN 824-6-6-B-NI	6	6	3	8	M 16 x 1.5	28	24	61.5	24	13.5	1.2	22	2	13	23	56
GN 824-8-7.5-B-NI	8	7.5	4	10	M 16 x 1.5	28	24	61.5	24	13.5	1.2	22	2	15	31	98
GN 824-9-8.5-B-NI	9	8.5	4.5	12	M 20 x 1.5	33	28	72.8	30	14.8	1.2	24	2	19	34	159

GN 824-BK

STAINLESS STEEL

Description	b1	l1	b2	d1 Plunger -0.02/-0.04 Bore H8	d2	d3	k	l2	l3	l4	l5	A/F1	A/F2	Spring load in N≈ Initial	Spring load in N≈ End	⚖️
GN 824-5-5-BK-NI	5	5	2.5	7	M 12 x 1.5	23	20	51.3	20	11.3	1	17	2	9	18	56
GN 824-6-6-BK-NI	6	6	3	8	M 16 x 1.5	28	24	61.5	24	13.5	1.2	22	2	13	23	75
GN 824-8-7.5-BK-NI	8	7.5	4	10	M 16 x 1.5	28	24	61.5	24	13.5	1.2	22	2	15	31	116
GN 824-9-8.5-BK-NI	9	8.5	4.5	12	M 20 x 1.5	33	28	72.8	30	14.8	1.2	24	2	19	34	195

GN 824-C

STAINLESS STEEL

Description	b1	l1	b2	d1 Plunger -0.02/-0.04 Bore H8	d2	d3	k	l2	l3	l4	l5	A/F1	A/F2	Spring load in N≈ Initial	Spring load in N≈ End	⚖️
GN 824-5-5-C-NI	5	5	2.5	7	M 12 x 1.5	23	20	51.3	20	11.3	1	17	2	9	18	46
GN 824-6-6-C-NI	6	6	3	8	M 16 x 1.5	28	24	61.5	24	13.5	1.2	22	2	13	23	53
GN 824-8-7.5-C-NI	8	7.5	4	10	M 16 x 1.5	28	24	61.5	24	13.5	1.2	22	2	15	31	96
GN 824-9-8.5-C-NI	9	8.5	4.5	12	M 20 x 1.5	33	28	72.8	30	14.8	1.2	24	2	19	34	157

GN 824-CK

STAINLESS STEEL

Description	b1	l1	b2	d1 Plunger -0.02/-0.04 Bore H8	d2	d3	k	l2	l3	l4	l5	A/F1	A/F2	Spring load in N≈ Initial	Spring load in N≈ End	⚖️
GN 824-5-5-CK-NI	5	5	2.5	7	M 12 x 1.5	23	20	51.3	20	11.3	1	17	2	9	18	55
GN 824-6-6-CK-NI	6	6	3	8	M 16 x 1.5	28	24	61.5	24	13.5	1.2	22	2	13	23	71
GN 824-8-7.5-CK-NI	8	7.5	4	10	M 16 x 1.5	28	24	61.5	24	13.5	1.2	22	2	15	31	114
GN 824-9-8.5-CK-NI	9	8.5	4.5	12	M 20 x 1.5	33	28	72.8	30	14.8	1.2	24	2	19	34	195



Assembly Instruction

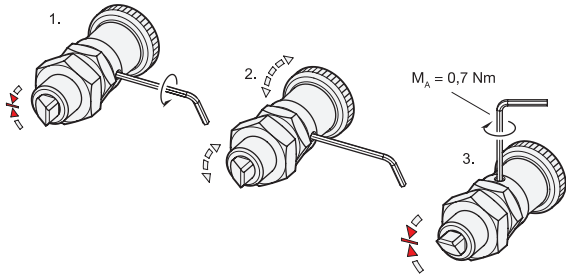

The position of the latching surface can be freely adjusted by 360°.

Installation steps:

1. Loosen the grub screw with a hex key.
2. Turn the knob to move the latching surface in the desired position.
3. Tighten the grub screw with a hex key.

Application Examples

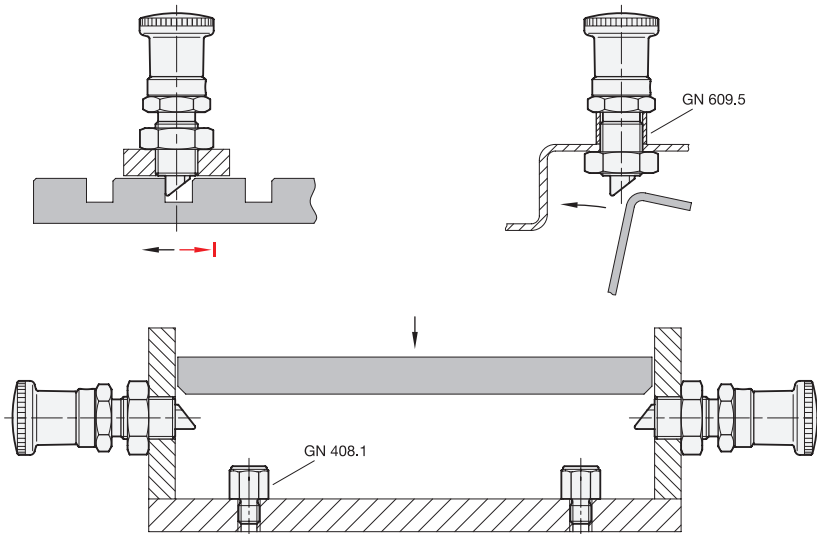

Indexing elements